



UNIVERSITY OF CAPE TOWN



DEPARTMENT OF COMPUTER SCIENCE

CS/IT Honours Final Paper 2020

Title: **Scaled Haptic Quarterstaff for VR**

Author: Riyaadh Abrahams

Project Abbreviation: VRProps

Supervisor(s): Prof James Gain

Category	Min	Max	Chosen
Requirement Analysis and Design	0	20	
Theoretical Analysis	0	25	
Experiment Design and Execution	0	20	
System Development and Implementation	0	20	
Results, Findings and Conclusions	10	20	
Aim Formulation and Background Work	10	15	
Quality of Paper Writing and Presentation	10		10
Quality of Deliverables	10		10
<u>Overall General Project Evaluation</u> (<i>this section allowed only with motivation letter from supervisor</i>)	0	10	
Total marks		80	

Scaled Haptic Quarterstaff for VR

Riyaadh Abrahams
University of Cape Town

ABSTRACT

VR has been reaching more homes in the past few years. Devices such as the Oculus and Vive as made VR more accessible and affordable. This has sparked an increase in the development of VR games and experiences. We have noticed that one of the biggest problems today is the ability to interact with these virtual worlds. The hand tracking and controllers allow us to do this, but everything we do is weightless as we feel no forces while interacting with virtual objects.

In this project, we built a haptic prop for a VR environment. A haptic prop is a physical representation of a virtual object. This allows it to feel like the virtual object by having an accurate texture and weight and size. The prop was designed to feel like a quarterstaff. When combined with a virtual representation in-game, it creates an immersive experience. The use of active and passive haptics was used to improve immersion and presence in a VR environment. The results showed that it was an improvement over the standard Vive controllers, as it has more weight, length, and realistic texture. This combined with vibrations and visual feedback proved a more immersive experience.

1 INTRODUCTION

Haptic feedback has many sub-areas. It can mainly be divided into active haptics and passive haptics. Active haptics (Force Feedback) makes use of haptic interfaces to simulate forces on our bodies, usually to help with interacting with virtual objects. Passive haptics makes use of static props to help provide realism to virtual worlds. A good example of this is a physical sword that is visually represented by a virtual sword. These passive props are combined with a visual representation to create a multi-modal 3D environment.

VR headsets, like the Oculus Rift and HTC Vive, include tracked controllers that act as passive haptic proxy objects. These are objects that physically represent virtual objects[18]. They also have motors to create vibrations for various interactions in VR environments. Vibrations, also called haptic pulses, can be fired when the user's hand collides with an object in the virtual world. The issue with these controllers is that they have limited physical properties with the virtual objects that they are representing. And it makes sense since the controllers are designed to be general-purpose and used in consumer VR headsets. They were not designed to simulate any specific virtual object. This can cause some immersion-breaking situations when dealing with some virtual objects. An example object is a quarterstaff, which we will be looking at closely in the research experiment.

We hope to develop a VR prop to improve immersion by using both active and passive haptics. The prop will represent a quarterstaff in a VR game.



Figure 2: Representation of a haptic prop in a virtual environment

2 RELATED WORK

2.1 Force Feedback

Force feedback can be categorized into kinesthetic feedback and tactile feedback. Kinesthetic feedback are things we feel in our muscles and tendons when forces are applied to them. It helps us identify the shape and structure of objects and is closely related to hand-eye coordination. Many of these systems are created by some sort of external force on our hands and body. These systems vary in size, weight, and degrees of freedom. Degrees of freedom (DoF) refers to the number of ways a rigid object can move through three-dimensional space. In the case of haptic technology, it is the number of ways our arms can move while bound to a haptic device. DoF is an important limitation to consider as it can affect the practical use cases of the haptic interface. A popular technique is using mechanical joints or links to our hands and fingers that apply forces and lock the movement in place at calculated positions in space. These are powered in a variety of ways, including pneumatics, hydraulics, and electrical motors. Kinesthetic feedback is used extensively in surgical machines [14]. Tactile feedback is sensed in our skin and especially our fingertips. It allows the detection of textures of objects. Both systems can help us increase immersion in virtual environments.

Kinesthetic feedback devices such as the haptic Arm Exoskeleton [5] have many practical benefits, such as training and rehabilitation. This consists of an exoskeleton that provides kinesthetic feedback to the joints of the lower arm and wrist of users. It has 5 degrees of freedom and can simulate large forces on the hands and arms. Some of the limitations are that the devices must be attached to the ground so there is no mobility of the user. There are also some limitations on the movement of the elbow. Researchers were eventually able to create the MGA Exoskeleton, an improved exoskeleton design [2]. The overall function was similar as it provided force Figure 1 - User operating the exoskeleton [5] feedback to the user's arms. One of the biggest differences is that they had a second haptic interface to interact with the upper arm as well. So instead of only the wrists

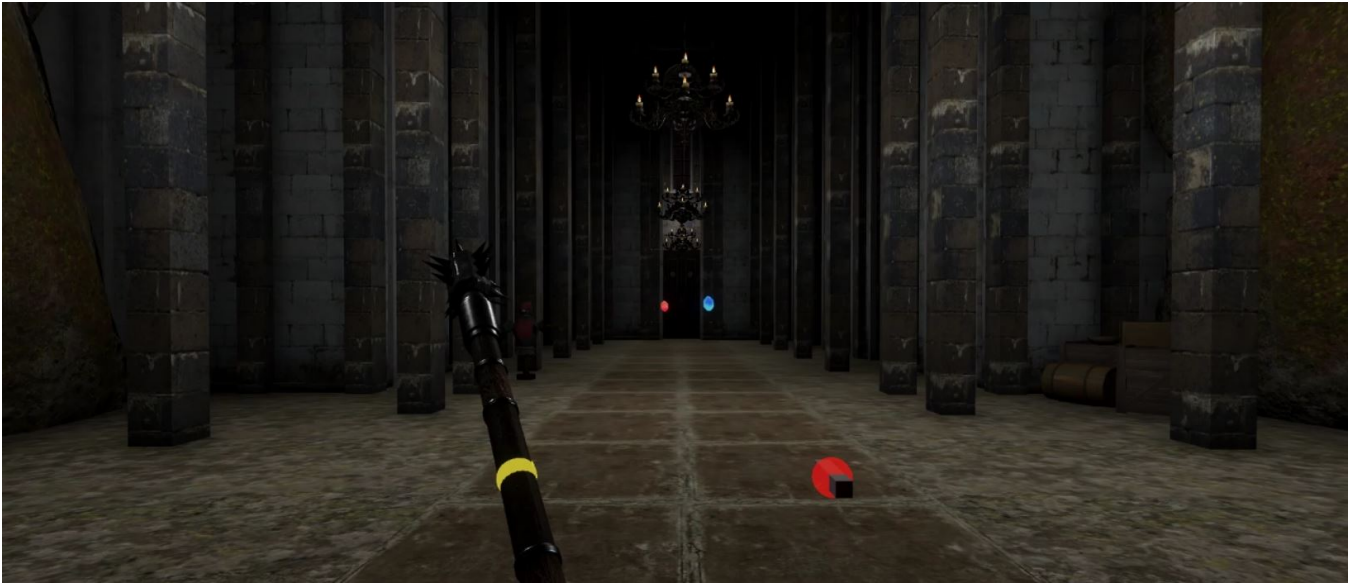

Figure 1: VR Environment design

and elbow, the entire arm was involved. This system provided 6 degrees of freedom which is an increase in the previous 5DOF.

Another big improvement is the direct integration with Virtual environments. These devices can become large and heavy. There are also ways of creating lightweight devices. Dexmo [4] is a lightweight mechanical exoskeleton that provides force feedback on the fingers. This is a good example of kinesthetic feedback. It provides 2 degrees of freedom for each finger. Digital actuators are used to lock the joints in place, and this provides the actual force and feeling of touching virtual objects. Dexmo is small and can be operated by an 800mAh battery. It is also much safer than larger pulley-based systems. They mention one of the key limitations is that only provides binary haptic feedback, which means you can tell when an object is there but cannot tell anything about how hard or soft it is. Researchers created a Haptic Dial System [8] to help in prototyping various knobs and dials. An example is a washing machine knob. They used motors to simulate different torque profiles along the rotational path. They were also able to switch the knobs with different shapes and sizes as this allowed prototyping of more products. They also combined the haptic feedback with visual and audio to create a truly multi-modal system. Many VR controllers have some form of vibrotactile feedback. This is especially useful when colliding with virtual objects. Various factors can impact the quality of haptic feedback. These include the type of motor, number of motors, alignment of the motors, and the intensity of the vibrations [13].

2.2 Passive Haptics

Passive haptics is when virtual objects have a 1 to 1 mapping to real-world objects. This allows for greater immersion without having to build complex electronics and robotics. A simple example of passive haptics is augmenting a virtual world with physical objects. [6]. One of the biggest immersion-breaking situations in VR is when you pass through another object. This can be reduced by adding physical objects in the same location as the virtual object. Insko

did some experiments by augmenting a VR cliff environment and added a physical ledge prop. They found that users experienced the environment as more realistic with the passive haptic prop. This was evidenced in increased heart rates and skin conductivity was higher. Passive haptics also provides the illusion of larger props and can be felt using smaller props. Researchers were able to simulate the feeling of holding a full-sized sword, using a much smaller prop. This is achieved using the haptic shape illusion [3]. One of the issues that emerge with passive haptics arises when we need to scale our experiences to many virtual objects. We cannot have a physical prop for every weapon in a VR game. There is a method called “haptic retargeting”, which leverages the dominance of vision when our senses conflict” [1]. This technique allows a single prop to provide passive haptics to multiple virtual objects. This is achieved by manipulating the world or the body to more accurately match the prop. The creators of VRGrabbers[16] used this technique to create a controller in the shape of a grabber or tongs. It allows you to grab things in the virtual world which makes you feel like you are grabbing it. What happens is the forces of the grabber pressing against itself are felt when it is closed and empty. The Visual representation is manipulated to make it seem like some object is in between the grabber tongs. The haptic retargeting allows the visual senses to be more dominant and therefore, you feel like you are grabbing something. The Vive tracker was used to track the grabber in the virtual world. Haptic retargeting works by using various warping techniques. Mahdi [1] speaks about the body, world, and hybrid warping. Body warping is when the virtual representation of the user’s body is altered such that the user contacts the real-world object at the perfect moment. World warping is when you alter the world coordinate system to allow alignment with real-world objects. Hybrid warping is a mix of the 2, which allows for a more effective illusion. If used correctly, these techniques can even change the shape of real-world objects. Keigo [9] made use of body warping, and rotational world warping to change the shape of a table. They were able to successfully create the illusion of a

triangle using only a square table. More warping techniques are being developed. Matthews [10] was able to combine body warping with a new “interface warping” to create a virtual interface of buttons using only 2 buttons on a panel. The one-button was used as a warp origin to assist the haptic re-targeting algorithms. Using this technique, any virtual interface layout could be created if it was inside the bounds of the physical panel and the algorithm would handle the re-targeting. This allows flexibility in interface design using a simple physical object.

3 DESIGN METHODOLOGY

3.1 Design Goals Constraints

The goals of our prop design can be split into passive haptic goals and active haptic goals.

In terms of passive haptic goals, the main goal of the prop is that it feels like a quarterstaff. We attempt to accurately simulate haptic properties such as weight, size, and texture. Some of the issues with standard VR controllers, like the Vive wands, is that the controllers have very little haptic properties in common with a quarterstaff. This means that it does not feel realistic as a physical representation of a quarterstaff as they are much lighter. They are also made out of plastic which is completely different from something like a wooden staff. The controllers are one-handed which means you will not be able to interact with the virtual quarterstaff with 2 hands. To help solve these issues, our VR prop must have a wooden texture, it must be heavy enough and it should have correct thickness. The dimensions do not need to be historically accurate but should allow for improved immersion in a VR environment. Some design constraints had to be met. The prop should not be too heavy as it can tire out the user’s arms. It should not be too long as this can be dangerous when using it in VR. It should be short enough to be able to use in a standard VR room-scale setup.

To satisfy the design requirements, the shaft of a large wooden spoon was used as a base for the prop. It has a thickness of 3.5cm and a length of 75cm which is a good approximation of a quarterstaff. It is made out of solid wood which means it already has quite a bit of weight to it. 75cm is long enough for 2 handed use but not too long so it is less likely to impact any objects in the room when swinging it around. The haptic shape illusion is a technique to create objects that feel larger than they are [3]. This is done by distributing weight in the correct areas of the prop. Since our quarterstaff is just a linear object, we would just need to add weight to the ends of the stick, to make it feel much longer than it is.

When looking at active haptic goals, there needed to be vibrations on both sides of the prop. This would increase realism as you can feel which part of the staff has been impacted in a game. The vibrations should be powerful enough and have variation. One of the design constraints is that the haptic pulses should have low latency. This is required to have a realistic feeling of interaction with the VR world. Another constraint is that the overall prop should be durable enough to swing around. The mounting of any electronics must be secure and able to handle fast swings.

These goals were achieved by mounting micro-controllers attached to vibration motors on each end of the stick. 3D printed mounts were designed to keep the electronics in place. bolts were used to securely mount the 3d printed parts onto the stick.

A Vive tracker was used to enable tracking on the prop in VR environments. The tracker was mounted on the side near the end of the stick. This allows sufficient space for 2 handed use of the prop.

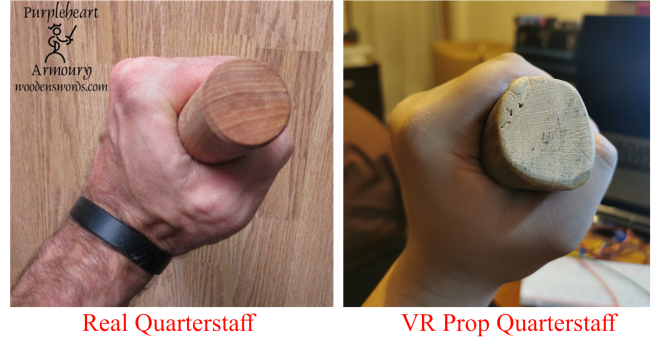

Figure 3: Comparison of diameter of a real quarterstaff to the prop

3.2 Electronics Design Methodology

When designing the electronics, there were a few problems that needed to be solved. The first problem was how the electronics would communicate with our game. The possible options are using a cable such as a USB cable, using a wireless connection such as WiFi or Bluetooth, and another solution is connecting to the output pins of the Vive tracker.

3.2.1 *Cable Connection.* The benefit of using a USB cable to connect directly to the computer is that it would have the lowest latency of all the solutions. The issue is that it will limit the ability to move and swing the prop around. Since we want our prop to move around freely, a wired connection is not the best choice.

3.2.2 *Vive Tracker output pin.* The Vive tracker has an output pin that can be used to connect to electronics. The benefit of using this is that it already is connected wirelessly to the Vive using their low latency wireless connection that the controllers use. It has a haptic feedback API for activating the pins. The issue with this approach is that you can only connect to a single vibration motor. The pins also produce low power signals so it would need to be amplified using another power source. It could be connected to 2 motors but they will not be individually controllable. Another issue would be that we would need to run wires across the stick, which could break immersion. Overall it could complicate the design.

3.2.3 *Wifi.* WiFi allows full mobility with the prop. It is easy to implement and would allow custom and precise control of the motors. The possible issue with WiFi is that the latency might be too much. This depends on the quality of the WiFi connection and the protocol chosen. When using WiFi to interact with the computer, multiple protocols could be used. An HTTP server, TCP(Transmission Control Protocol) server, Or UDP(User Datagram Protocol) server could be used. TCP causes higher latency because there needs to be a connection between the 2 devices. TCP also implements reliable data transfer which increases the time a message takes to send. If a packet gets dropped along the way, it will resend it. In our case, this would cause delayed haptic pulsed

which can decrease the immersion and confuse users. UDP protocol does not set up any connections, it just listens for packets being sent, any packets that are lost along the way will not be resent. Packets are not likely to be lost if the WiFi access point is close. Overall, UDP is best suited for real-time data which is what we have. It has the lowest latency and is also simple to

3.3 Electronics Implementation

Each side of the stick consists of:

- NodeMCU V3 Micro-controller (Arduino compatible)
- L298n motor driver
- 2 Vibration motors (from a PlayStation 4 controller)
- 9V Battery

The reason for use of a NodeMCU as the micro-controller is that it has built-in Wifi and can be programmed using the Arduino IDE. It is also small enough to easily mount onto the prop.

A 9V battery was used as a power source. The benefit of this is that they are common and easily replaceable. You can also get rechargeable versions of them. 9V batteries are compact and also adds weight which helps increase the overall weight. It also has enough voltage to power the motors as well as the NodeMCU. There are some issues with 9V batteries. They usually have low capacity and cannot constantly spin motors for very long. This is okay in our case as we only fire the motors to spin in small pulses. The batteries last long enough for our use case.

The L298n motor driver allows power to safely be distributed to the motors and the micro-controller from the 9V battery. It allows the speed of the motor to be controlled using code. The NodeMCU pins are connected to the driver using jumper cables. These pins can control the direction and speed of the motors. There is a total of 6 pins on the L298n motor driver. 3 pins for each motor. 2 of the 3 pins are used to control direction. the third pin is used to control the speed using PWM signals. PWM, also known as Pulse Width Modulation is a method of simulating analogue signals by providing a digital signal that switches on and off at specific rates. There is one pulse of fixed magnitude in every PWM period. However, the width of the pulses changes from pulse to pulse according to a modulating signal.[17]

The micro-controller connects to a local WiFi network and hosts a UDP server. It listens for messages and when received, it fires a haptic pulse. Multiple messages have been configured based on different messages. eg "Hard", "Medium" and "Light". This allows precise control of motor vibrations from any device connected to the same WiFi network. A mobile hotspot was used so that the micro-controllers do not have to be reprogrammed when the location changes. The username and password are hardcoded. So each time you want to use a new WiFi network, you need to recompile the code for each micro-controller.

3.4 3D Printing

The main design goal for the mount is that it can securely hold all the electronic components. It should also be tightly mounted on the stick so that nothing is loose while in use. Some design constraints are that the mount should be large enough to hold all the components, but not too large that it increases the chance of accidents while using it. There was also a choice on whether the

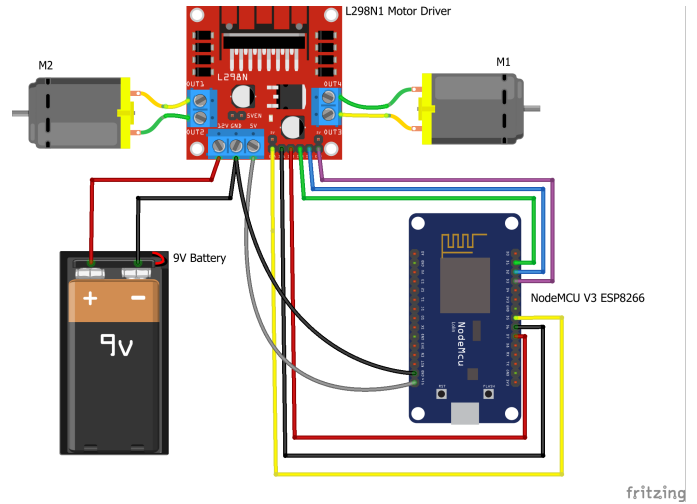

Figure 4: Electronics Sketch of one side of the prop

components should be completely enclosed or exposed. Creating a mount where the electronics are exposed can decrease the durability of the prop in case of any accidental impacts. But creating a fully enclosed mount would require more complex 3d modelling as well as more design iterations.

3.4.1 *Constructive Solid Geometry*. "Constructive Solid Geometry (CSG) is a powerful way of describing solid objects for computer graphics and modelling. The surfaces of any primitive object (such as a cube, sphere or cylinder) can be approximated by polygons. Being able to find the union, intersection or difference of these objects allows more interesting and complicated polygonal objects to be created." [12] Using CSG operations, we can take a cube and "cut out" sections of smaller cubes and cylinders. If we get these to be the correct size, then it will allow the components to fit.

It was decided to have a simple cube, with cutouts for each component as well as a cut out for the stick to be attached. This was simple to design using accurate sizes of the components. The more complex the design would mean more iterations would have to be made to fix all the errors. This design was completed in only 2 iterations since it was a single solid object. Even though some of the components are exposed, They are securely mounted and not fragile. Only the motor driver is fully exposed which is quite durable. The micro-controllers are enclosed in a battery enclosure to keep it safe. We could have some sort of lightweight outer enclosure but this design is acceptable for this project.

Holes also needed to be modelled to allow bolts to secure the mount in place. the CSG operations made this easy since all that was needed was to include extra cylinders to subtract from the cube model until all the holes were in place

All the modelling was done in Blender3D which is powerful and open source. Blender has good support for CSG operations that are non-destructive. This means that the original model cutouts are adjustable at any point. This feature proved helpful when it was needed to change the size of the cutouts for the motors. Blender also supports exporting in formats that are supported by 3D printers. The Creality Ender 3 printer was used to print the mounts. 2

design iterations were needed to get the correct sizes for all the components.

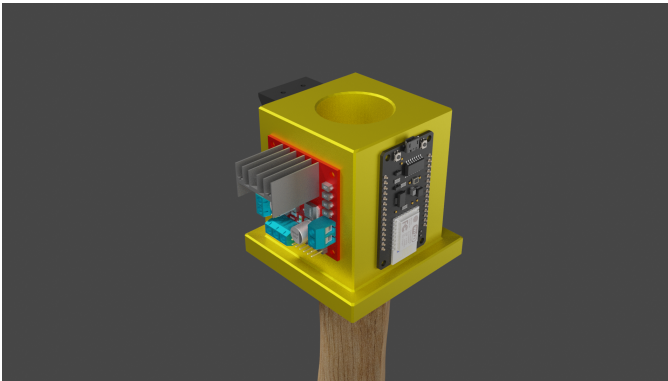

Figure 5: 3D printed model render

4 GAME DESIGN METHODOLOGY

Unity 3D was used to build the game. It has good support for VR and allows for quick iterations.

4.1 Gameplay and Interaction

The design goals for the game is to be as immersive as possible. It is also important that the users use the full range of motion of a quarterstaff. The game should be built in a way where the user would need to move the prop at different angles and speeds to that the full haptic feedback can be experienced.

This was achieved by building a game where the user has to swing at oncoming floating gems. The goal of the game is to score as many points as possible by destroying gems that are floating towards you. Each time the player misses an obstacle, they lose health and eventually the game ends.

Gems are grouped into blocks. Multiple blocks are added to a pool which is randomly selected every few seconds. this allows the game to be built predictably while still having some randomness. If it were just single gems being randomly selected at a random position, it might cause certain cases where the game has some impossible combinations that the user will not be able to swing at in time. So custom created blocks allow for a pseudo-random system that can be customized and set up in specific interesting positions. An example would be having a blue gem on the left, a red gem in the middle, and another blue gem on the right. For the user to correctly shatter all these gems, they would need to swing the prop in a specific way. This is the kind of control that is needed to build a game such that the user can do specific movement and feel the benefits of the haptic prop.

4.2 Environment Design

The VR environment is set inside a medieval cathedral. This is an indoor environment with dim lighting. The setting looks like a reasonable scene to be using a quarterstaff. This helps with immersion. The virtual representation of the staff is longer than the actual prop, but due to the haptic shape [3], it feels like the length is correct. This is due to the weight of the prop as well as the visual feedback of the virtual staff. The gems are brightly coloured and create a

particle effect when it is destroyed. A shattered glass sound effect also plays to increase immersion.

The most important aspect for the environment design is that it should maximise the feeling of presence. "Presence is defined as the subjective experience of being in one place or environment, even when one is physically situated in another." [15]. We want the user to feel like they are in a different environment. This increases the immersiveness of the game and hopefully increases the fun. There are various ways to build a VR environment to improve the feeling of presence. Witmer speaks about various factors that contribute to a sense of presence.

4.2.1 Immediacy of control. When a user does something in the VR environment, they should get immediate feedback. This is implemented using particle effects as well as sound effects when a gem is broken.

4.2.2 Anticipation. Witmer mentions that higher presence will be experienced when the user can predict what will happen next. Since our game has gems floating towards the user, they can predict when it will be in range to hit. This allows us to create anticipation and increase presence.

4.2.3 Mode of control. They state that presence is increased when the interactions with the world are familiar and natural. Since the only interaction our user has with the world is through the haptic prop, it feels less artificial and therefore successfully implements a good mode of control.

4.2.4 Sensory modality. This factor speaks on the different combination of senses that are used together to increase presence. Some senses are more dominant than others. The visual channel is the most dominant which is why there was a lot of focus on the visual aspects of the virtual environment. This begins with an accurate scale of the objects in the environment. The cathedral is large and accurate. All the other objects in the scene are also realistically sized. This is complemented by good lighting and materials. The brightness of lights in the scene is animated to make it feel like the source is coming from candles. All the candle textures in the scene are animated as well. All these visual elements are combined with some background music and sound effects when gems shatter. The audio channels are less dominant than the visual. There is also the haptic properties of the prop that helps to create a good combination of sensory channels.

4.2.5 Degree of movement perception. The presence is enhanced if the user has a realistic sense of movement within the world. Since we are using the Vive, it means we do have 6 degrees of freedom when moving around the environment. This is the 3 rotation motions that are detected as well as 3 axes of position that the user can move around in. This means they can walk around the world and everything will change as if they are actually there. The only way to move in our VR environment is by moving in real life. We do not have any other forms of locomotion like teleportation or smooth artificial movement using a controller. This increases presence and also decreases the chance of VR sickness which can be caused by artificial movement mechanics.

Table 1: Heuristic evaluation results

Problem	Priority	Heuristic Principle Affected
Controller		
Potential strain if you have to switch direction to hit different colours. (Twisting hand upside down)	N/A	Natural engagement, close coordination of action and representation
Harder to hit things on the bottom. Controller is not symmetric.	N/A	Strain, Natural expression of action
Game		
Gems could come from different directions and range more in height and speed. Needs range in difficulty and test of range of staff motion.	HIGH	Close coordination of action and representation, Compatibility with user's task and domain
No score or stats.	HIGH	Compatibility with user's task and domain
spawning of gems is strange, needs a physical explanation (e.g., a canon or monster) and something being defended behind you. Narrative element.	MEDIUM	Natural engagement, sense of presence
Game fundamentally doesn't test reaching because the gems always come within reach.	HIGH	close coordination of action and representation, Compatibility with user's task and domain
no conflict. Needs a failure mechanic. Could leverage a guardian aspect.	LOW	Compatibility with user's task and domain
grounding staff should cause rumble feedback. Support for other gestures, such as bumping a lever.	MEDIUM	Realistic feedback
particle effect on gem break would be more immersive.	LOW	Sense of presence, realistic feedback Compatibility with user's task and domain, realistic feedback, natural expression of action
hitting the wrong gem should have a negative effect	HIGH	Sense of presence, realistic feedback, natural expression of action
Prop		
Seems like there is a time delay on rumble – mostly for red gems	HIGH	close coordination of action and representation
Needs a protective case around electronics. Concerns that might break the staff.	MEDIUM	Sense of presence

Overall, the environment design was heavily focused on increasing immersion and presence. Everything from visual to audio to haptics should work together to create an immersive environment.

5 EVALUATION

5.1 Heuristic Evaluation

In a heuristic evaluation, specialists study the interface in-depth and look for properties that, they know from experience, will lead to usability problems[7]. The benefits of doing a heuristic evaluation are it is cheap, It is intuitive and it is easy to motivate people to do it and it does not require advance planning [11]. The problems are also categorised by its severity which helps focus on the most important ones.

A heuristic evaluation was done with 3 VR experts, which is enough evaluators to find the majority of the problems. Neilson[11]

found that in some experiments, 3-5 experts can point out 80%-90% of the problems.

The evaluators 1st played the game using the regular Vive controllers. They then used the haptic prop. All the problems were recorded and were summarized in table 1. Along with the standard heuristic evaluation, the evaluators were asked to point out their general thoughts and any positive aspects of the design.

5.1.1 Positive feedback from the heuristic evaluation. The gloomy environment and lighting really helped in increasing the immersion of the game. The scale of all the objects in the scene was realistic enough that it did not break immersion. The haptic feedback was effective when breaking gems, and the sound effects and particle effects were all in sync to really convince the player of an impact to the prop. The combination of passive haptics such as weight and texture with active haptics of vibrations feedback in sync with visual and audio feedback was an effective multi-modal stimulation

that increased the sense of presence. All the evaluators really that the prop could be held and swung with two hands. It added to the immersion as was easier to use, despite being heavier than the controller. The Vive tracker worked perfectly and was mounted on a good position and calibrated correctly. The weight of the prop was correct and successfully gave an illusion of an exaggerated length in the virtual environment. For the most part, there were not much latency issues, and the vibrations were synchronized with visual and audio feedback.

6 DISCUSSION

After testing the prop, it was clear that it was a huge improvement over the Vive controller. All the passive haptic properties had an impact on the experience. The wooden texture, the weight and length helped to increase immersion. An interesting observation was that the users felt less tired while using the prop as opposed to the Vive controllers which is much lighter. This is due to the fact that the prop is two-handed, whereas the controller is one-handed, which means you have to turn your entire arm to rotate the quarterstaff in-game. So the ability to use two hands helped in reducing the fatigue, even though the prop is substantially heavier than the Vive controllers. This was unexpected, as a huge concern was that users would get tired after a short amount of time in-game. Some evaluators were in the game for up to 25 minutes without getting tired.

None of the evaluators experienced VR sickness or dizziness. This was most likely since all of them have had lots of experience in VR. There was also no artificial player movements, such as acceleration or even smooth motion. This was a room-scale experience, which means all the movement occurred by the user actually walking around the space.

Another huge concern was that the haptic vibrations would have too much latency. There was in fact a small issue with that. It was not very frequent, but some haptic pulses were slightly delayed. This could be caused by the use of a mobile hotspot as an access point. There was no notable delay when connecting to a home WiFi network in previous tests. It seemed that most of the delays were happening on one side of the prop. It could possibly be caused by the position of the electronics on the stick. It would have been better to use a proper WiFi access point in the testing environment, but that would be much more time consuming to set up, as the IP addresses would not match the ones in the game. It might have been better to take the extra time and set up a more reliable connection.

All of the evaluators felt that it was a bit risky to have the electronics exposed. The prop did feel solid enough for them to spin and swing it around but thought it would be better to have it fully enclosed. Mainly so that the wires do not get damaged or pulled out. The main issue with creating a full enclosure is that it would take much more time and iterations to design and model it. The 3D printed enclosure could also be improved by modeling actual pathways for the wires so that it is not just hanging off the prop.

Although the game did have some variation and randomness, there was not enough. There could be more gem combinations that allow for more complex swinging of the prop. This is a relatively quick fix as we just need to create more blocks that can be added to

the pool for random spawning. Some of the other changes require redesigns whereas this is more iterative.

There was an issue that also affected the immersion of the game. The gems were spawning in the distance without and story or reason behind it. The game would be much more immersive if there was a reason for the gems being spawned. Maybe an enemy is firing them and you are defending something. Fundamentally, the game had a lack of story or purpose. This can be improved by adding more dynamic enemies and an introduction that lays out the story of the game.

All the participants were genuinely satisfied with the weight of the prop. One of the evaluators thought the virtual quarterstaff was a bit too short. It was longer than the physical prop and it did feel longer in VR, but we could improve a bit on the exact length. However, the haptic shape illusion was successful. The wooden texture and weight of the prop especially helped in increasing the sense of presence. This was also enhanced by the wooden texture on the virtual prop. All the passive haptic properties were the biggest successes of the project. The haptic vibrations added to the experience, but it was the passive haptics that primarily sold the idea of swinging a quarterstaff. The prop itself can be improved by fixing some usability issues with turning it on. Switches can be added to each side to make it easier to turn on and start using. Overall, the prop was much better than the Vive controller.

7 CONCLUSION

In conclusion, the haptic prop proved to be much better than the Vive controllers when it comes to having a sense of presence. The combination of passive haptics, active haptics, visual and audio feedback as well as an element of focusing on the task at hand all worked together in creating an immersive experience. Evaluators found it not only more enjoyable but also easier and less fatiguing to use a heavier, two-handed custom prop to swing at incoming obstacles. The haptic pulses have a low enough latency to provide a convincing and satisfying feeling of interacting with a virtual world. There are definitely many things that could have been improved, and lots of opportunity for future exploration in this area of study. For example, there is a much better solution for mounting the electronics such that everything is fully enclosed. There could also be a way to adjust the weights of the prop as needed to create a longer virtual representation. Overall, the results proved successful.

REFERENCES

- [1] Mahdi Azmandian, Mark Hancock, Hrvoje Benko, Eyal Ofek, and Andrew D Wilson. 2016. Haptic retargeting: Dynamic repurposing of passive haptics for enhanced virtual reality experiences. In *Proceedings of the 2016 chi conference on human factors in computing systems*. 1968–1979.
- [2] Craig Carignan, Jonathan Tang, and Stephen Roderick. 2009. Development of an exoskeleton haptic interface for virtual task training. In *2009 IEEE/RSJ International Conference on Intelligent Robots and Systems*. IEEE, 3697–3702.
- [3] Eisuke Fujinawa, Shigeo Yoshida, Yuki Koyama, Takuji Narumi, Tomohiro Tanikawa, and Michitaka Hirose. 2017. Computational design of hand-held VR controllers using haptic shape illusion. In *Proceedings of the 23rd ACM Symposium on Virtual Reality Software and Technology*. 1–10.
- [4] Xiaochi Gu, Yifei Zhang, Weize Sun, Yuanzhe Bian, Dao Zhou, and Per Ola Kristensson. 2016. Dexmo: An inexpensive and lightweight mechanical exoskeleton for motion capture and force feedback in VR. In *Proceedings of the 2016 CHI Conference on Human Factors in Computing Systems*. 1991–1995.
- [5] Abhishek Gupta and Marcia K O'Malley. 2006. Design of a haptic arm exoskeleton for training and rehabilitation. *IEEE/ASME Transactions on mechatronics* 11, 3 (2006), 280–289.

- [6] Brent Edward Insko, M Meehan, M Whitton, and F Brooks. 2001. *Passive haptics significantly enhances virtual environments*. Ph.D. Dissertation. University of North Carolina at Chapel Hill.
- [7] Robin Jeffries, James R Miller, Cathleen Wharton, and Kathy Uyeda. 1991. User interface evaluation in the real world: a comparison of four techniques. In *Proceedings of the SIGCHI conference on Human factors in computing systems*. 119–124.
- [8] Laehyun Kim, Manchul Han, Sang Kyun Shin, and Se Hyung Park. 2008. A haptic dial system for multimodal prototyping. In *18th international conference on artificial reality and telexistence (ICAT 2008)*.
- [9] Keigo Matsumoto, Takeru Hashimoto, Junya Mizutani, Hibiki Yonahara, Ryohei Nagao, Takuji Narumi, Tomohiro Tanikawa, and Michitaka Hirose. 2017. Magic table: deformable props using visuo haptic redirection. In *SIGGRAPH Asia 2017 Emerging Technologies*. 1–2.
- [10] Brandon J Matthews, Bruce H Thomas, Stewart Von Itzstein, and Ross T Smith. 2019. Remapped Physical-Virtual Interfaces with Bimanual Haptic Retargeting. In *2019 IEEE Conference on Virtual Reality and 3D User Interfaces (VR)*. IEEE, 19–27.
- [11] Jakob Nielsen and Rolf Molich. 1990. Heuristic evaluation of user interfaces. In *Proceedings of the SIGCHI conference on Human factors in computing systems*. 249–256.
- [12] Aristides AG Requicha and Herbert B Voelcker. 1977. Constructive solid geometry. (1977).
- [13] Simon Schätzle, Thomas Hulin, Carsten Preusche, and Gerd Hirzinger. 2006. Evaluation of vibrotactile feedback to the human arm. In *Proceedings of EuroHaptics*. 557–560.
- [14] Sebastian Schostek, Marc O Schurr, and Gerhard F Buess. 2009. Review on aspects of artificial tactile feedback in laparoscopic surgery. *Medical engineering & physics* 31, 8 (2009), 887–898.
- [15] Bob G Witmer and Michael J Singer. 1998. Measuring presence in virtual environments: A presence questionnaire. *Presence* 7, 3 (1998), 225–240.
- [16] Jackie Yang, Hiroshi Horii, Alexander Thayer, and Rafael Ballagas. 2018. VR Grabbers: Ungrounded Haptic Retargeting for Precision Grabbing Tools. In *Proceedings of the 31st Annual ACM Symposium on User Interface Software and Technology*. 889–899.
- [17] Zhenyu Yu, Arefeen Mohammed, and Issa Panahi. 1997. A review of three PWM techniques. In *Proceedings of the 1997 American Control Conference (Cat. No. 97CH36041)*, Vol. 1. IEEE, 257–261.
- [18] Andre Zenner and Antonio Krüger. 2017. Shifty: A weight-shifting dynamic passive haptic proxy to enhance object perception in virtual reality. *IEEE transactions on visualization and computer graphics* 23, 4 (2017), 1285–1294.